



PDHonline Course C758 (1 PDH)

**Non-Residential Floodproofing for
Buildings Located in Special Flood
Hazard Areas**

Instructor: Vincent D. Reynolds, MBA, PE

2020

PDH Online | PDH Center

5272 Meadow Estates Drive
Fairfax, VA 22030-6658
Phone: 703-988-0088
www.PDHonline.com

An Approved Continuing Education Provider

Non-Residential Floodproofing — Requirements and Certification

for Buildings Located in Special Flood Hazard Areas

in accordance with the

National Flood Insurance Program

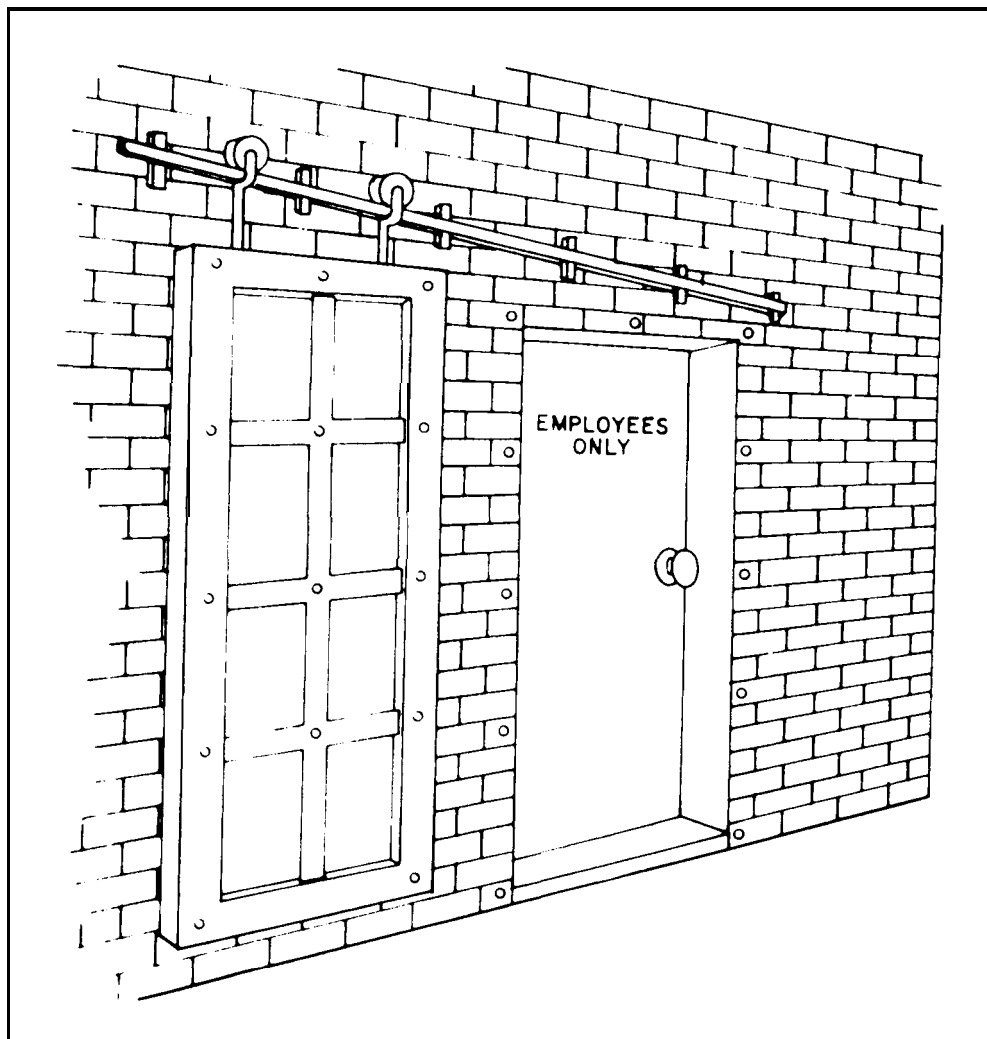

Key Word/Subject index:

This index allows the user to quickly locate key words and subjects in this Technical Bulletin. The Technical Bulletin User's Guide (printed separately) provides references to key words and subjects throughout the Technical Bulletins. For definitions of selected terms, refer to the Glossary at the end of this bulletin.

| Key Word/Subject | Page |
|--|------|
| A-zone floodproofing | 2 |
| Floodproofing, Emergency Operations Plan, minimum acceptable | 5 |
| Floodproofing, Inspection and Maintenance Plan, minimum acceptable | 5 |
| Floodproofing, recognition of for insurance rating purposes | 4 |
| High hazard area, safety and access in | 3 |
| Hydrodynamic forces on floodproofed building | 8 |
| Hydrostatic forces on floodproofed building | 6 |
| Non-residential floodproofing certificate, how to fill out | 10 |

Any comments on the Technical Bulletins should be directed to:

FEMA/FIA
Office of Loss Reduction
Technical Standards Division
500 C St., SW, Room 417
Washington, D.C. 20472

Technical Bulletin 3-93 replaces Technical Bulletin 90-3 (draft) "Non-Residential Floodproofing Certification Requirements."

Graphic design based on the Japanese print *The Great Wave Off Kanagawa*, by Katsushika Hokusai (1760-1849), Asiatic collection, Museum of Fine Arts, Boston.

TECHNICAL BULLETIN 3-93

Non-Residential Floodproofing — Requirements and Certification for Buildings Located in Special Flood Hazard Areas in accordance with the National Flood Insurance Program

Introduction

This bulletin describes design, construction, and planning requirements for the floodproofing of non-residential buildings under the National Flood Insurance Program (NFIP) regulations and how to correctly complete the NFIP's Floodproofing Certificate for Non-Residential Structures form. For the purposes of this bulletin, floodproofing means making a building watertight, substantially impermeable to floodwaters.

Before a floodproofed building is designed, numerous planning considerations, including flood warning time, uses of the building, mode of entry to and exit from the building and the site in general, floodwater velocities, flood depths, debris impact potential, and flood frequency, must be addressed to ensure that dry floodproofing will be a viable floodplain management tool. These critical considerations are discussed within this bulletin.

In the FEMA publication "Floodproofing of Non-Residential Structures," floodproofing is described as a combination of adjustments and/or additions of features to buildings that eliminate or reduce the potential for flood damage. Examples of such adjustments and additions include anchoring of the building to resist flotation, collapse, and lateral movement; installation of watertight closures for doors and windows; reinforcement of walls to withstand floodwater pressures and impact forces generated by floating debris; use of membranes and other sealants to reduce seepage of floodwater through walls and wall penetrations; installation of pumps to control interior water levels; installation of check valves to prevent the entrance of floodwater or sewage flows through utilities; and the location of electrical, mechanical, utility, and other valuable damageable equipment and contents above the expected flood level.

Floodproofing components for an individual building may also include floodwalls, small localized levees, or berms around buildings. However, such components, because they are not part of the building itself, are generally not credited for the flood insurance rating of a building under the NFIP and are therefore not detailed within this bulletin.

The NFIP allows a new or substantially improved non-residential building in an A zone (Zone A, AE, A 1-A30, AR, AO, or AH) to have a lowest floor below the base flood elevation (BFE), provided that the building has been designed, constructed, and certified to be floodproofed and to meet established criteria. Floodproofing of areas below the BFE in residential buildings is not permitted under the NFIP. In a Coastal High Hazard Area (Zone V, VE, or V 1 -V30), construction or substantial improvement of a building with a lowest floor elevation below the BFE is not allowed, regardless of any floodproofing techniques employed.

A Floodproofing Certificate for Non-Residential Structures (FEMA Form 81 -65) has been developed by FEMA for use in the certification of non-residential floodproofing designs. Because of the increased potential for significant building damage due to the failure of the floodproofing system, the NFIP requires a design certification for all floodproofed buildings. In

accordance with Section 60.3(c)(4), communities shall require a correctly completed certificate (or its equivalent) for every floodproofed building within a Special Flood Hazard Area (SFHA) and shall maintain the completed certificates on file.

A Floodproofing Certificate for Non-Residential Structures is required for the following types of buildings (in A zones only):

- Floodproofed non-residential buildings (no residential uses).
- Floodproofed mixed-use buildings that are professionally designed with all residential uses located above the floodproofing design elevation.

NFIP Regulations

The NFIP regulations that specifically apply to the design of floodproofing for non-residential buildings are within Section 60.3(c)(3), which states that the community shall:

“Require that all new construction and substantial improvements of non-residential structures within Zones A1 -A30, AE, and AH on the community’s FIRM (i) have the lowest floor (including basement) elevated to or above the base flood level, or (ii) together with attendant utility and sanitary facilities, be designed so that below the base flood level the structure is watertight with walls substantially impermeable to the passage of water and with structural components having the capability of resisting hydrostatic and hydrodynamic loads and effects of buoyancy. ”

Section 60.3(c)(8) further states that the community shall:

“Require within any AO zone on the community’s FIRM that all new construction or substantial improvements of non-residential structures (i) have the lowest floor (including basement) elevated above the highest adjacent grade at least as high as the depth number specified in feet on the community’s FIRM (at least two feet if no depth number is specified), or (ii) together with attendant utility and sanitary facilities, be completely floodproofed to that (base flood) level to meet the floodproofing standard specified in paragraph 60.3(c)(3)(ii).”

Additionally, Section 60.3(c)(4) requires that any floodproofing design be certified in the following manner:

“Provide that where a non-residential structure is intended to be made watertight below the base flood level, (i) a registered professional engineer or architect shall develop and/or review structural design, specifications, and plans for the construction, and shall certify that the design and methods of construction are in accordance with the accepted standards of practice for meeting the applicable provisions of paragraphs (c)(3)(ii) or (c)(8)(ii) of this section, and (ii) a record of such certificates which includes the specific elevation (in relation to mean sea level) to which such structures are floodproofed shall be maintained with the official designated by the community... ”

It should be noted that Technical Bulletins provide guidance on the minimum requirements of the NFIP regulations. Community or State requirements that exceed those of the NFIP take precedence. Design professionals should contact the community to determine whether more restrictive local or State regulations apply to the building or site in question. All applicable standards of the State or local building code must also be met for any building in a flood hazard area.

Planning Considerations

A review of the following factors for the site in question will assist the design professional in determining whether floodproofing is appropriate. For example, if a site will be surrounded by rapidly rising, high-velocity floodwaters during a flood, and the available warning time is short, then the site is unsuitable for a floodproofed building.

Warning Time

The rate-of-rise of floodwaters for the site in question, the established flood warning system (if any), the flood warning time available, and the reliability of the flood warning must be reviewed to determine appropriate floodproof design elements. The rate-of-rise or the flood warning time available through an existing reliable (community-based or regionally based) flood warning system must be adequate to provide sufficient lead time to evacuate a floodprone building when flooding threatens. In addition, sufficient warning time must exist to successfully place floodproofing components, such as removable flood shields or gates, if such components are to be included in the floodproofing design. Other examples of floodproofing techniques that can require human intervention are operating sump pumps and closing valves. The amount of time necessary to put human intervention floodproofing components in place will depend upon the number of components, their complexity, and the availability of personnel to place them. Floodproofed buildings are not appropriate for any site in a flash flood area, because of the potentially short warning time.

Safety and Access

Safe access to a floodproofed building is a critical factor in the determination of whether floodproofing is an appropriate design alternative. In 1987, Colorado State University conducted a study of human stability in flood flow conditions based on the product number of depth of flow multiplied by the floodwater velocity. Results of this study indicated that any floodplain location with a product number of 4 or greater represents a significant hazard to individuals. Floodplain sites with a base flood product number number of 4 or greater (depth in feet multiplied by velocity in feet per second) will create a hazard for anyone attempting to escape from or gain access to the site. Such sites are not generally acceptable for floodproofed buildings, unless modifications are made to the site to reduce the flood hazard.

For any floodproofed building, all roads to be used as evacuation routes must remain passable as the floodwaters rise. In addition, all roads that provide access to buildings whose dry-floodproofing components require human intervention must remain passable long enough for the

floodproofing components to be installed and for all personnel to safely evacuate the site. For sites with an acceptably low hazard (product number less than 4) that are contiguous to land above the BFE, evacuation and access during times of flooding are generally not critical considerations.

Flood Velocities, Flood Depths, and Debris

For sites with flood velocities in excess of 5 feet per second or base flood depths in excess of 3 feet, the cost of dry-floodproofed construction may be prohibitive. Part 3 of the section of this bulletin titled “Minimum Engineering Considerations” describes the flood forces that a floodproofed building must be able to resist. Flood-borne debris can generate impact forces that may make a dry-floodproofed design technically infeasible and therefore inappropriate. A level of safety above the BFE, referred to as freeboard, is recommended, as discussed under “Minimum Engineering Considerations. ”

Note: While buildings need only be protected to the BFE for floodplain management purposes, freeboard is considered for flood insurance rating purposes. Because of the additional risk associated with any floodproofed building, 1 foot is subtracted from the elevation to which a building has been floodproofed, for insurance rating (if the building is floodproofed at least to the BFE). Therefore, to receive an insurance rating based on 100-year flood protection, the building must be floodproofed to an elevation at least 1 foot above the BFE. Insurance premiums will be lower if floodproofing exceeds this requirement.

Flood Frequency

A site that has been flooded frequently may not be appropriate for a dry-floodproofed building. The cumulative wear-and-tear on a building’s external components as a result of recurring inundation may render a dry floodproofing strategy infeasible. The cost of repeated business interruption and of frequent cleanup activities, as well as the effects of having to repeatedly implement a flood emergency plan, must be assessed.

If the evaluation of each of the aforementioned factors indicates that dry floodproofing is a viable floodplain management alternative, then a floodproofing design is developed. For all floodproofed buildings, the design professional must then produce both a Flood Emergency Operation Plan and an Inspection and Maintenance Plan for the building.

Flood Emergency Operation Plan

A Flood Emergency Operation Plan is an integral part of any building’s floodproofing design and is critical when the floodproofing requires human intervention such as the installation of flood gates or flood shields. A Flood Emergency Operation Plan is necessary for any floodproofed building to ensure that the floodproofing components will operate properly under all conditions, including power failures. A continuous source of electricity to operate any necessary floodproofing components, such as pumps, will be needed for any floodproofing design that

includes such components. The design professional must produce the plan. An adequate plan must include the following:

1. An established chain of command and responsibility with leadership responsibilities clearly defined for all aspects of the plan.
2. A procedure for notification of necessary parties when flooding threatens and flood warnings are issued. Personnel required to be at the building should have a planned and safe means of ingress and should have no other emergency response duties during a flood event. Alternates should be assigned in the event that the primary persons responsible are unable to complete their assigned duties under the plan.
3. A list of specific duties assigned to ensure that all responsibilities are addressed expeditiously. The locations of materials necessary to properly install all floodproofing components must be included in the list.
4. An evacuation plan for all personnel—those without duties for the flood emergency as well as those with duties for implementing the plan. All possible ingress and egress routes must be identified.
5. A periodic training and exercise program to keep personnel aware of their duties and responsibilities. Training drills should be held at least once a year and should be coordinated with community officials. Flood safety precautions should be repeated during each training drill.

Inspection and Maintenance Plan

Every floodproofing design requires some degree of periodic maintenance and inspection to ensure that all components will operate properly under flood conditions. The necessary inspection and maintenance activities, including inspection intervals and repair requirements, must be described in the Inspection and Maintenance Plan. Components that should be inspected as part of an annual (as a minimum) maintenance and inspection program include the following:

1. Mechanical equipment such as sump pumps and generators.
2. Flood shields and closures, to ensure that they fit properly and that the gaskets and seals are in good working order, properly labeled, and stored as indicated in the Flood Emergency Operation Plan.
3. Walls and wall penetrations, for cracks and potential leaks.
4. Levees and berms, for excessive vegetative growth, cracks, or leaks.

Both the Flood Emergency Operation Plan and the Inspection and Maintenance Plan are necessary at the time that the Non-Residential Floodproofing Certificate is submitted to the community. Before issuing a building permit, the community should require that the property owner sign an agreement stating that the plan will be adhered to. The community should also be assured that the inspection and maintenance activities required by the plan will continue regardless of changes in the ownership of the floodproofed building. This assurance should be accomplished by appropriate deed restrictions. Any lease agreement should also contain clear language stating the leaseholder's responsibilities for the floodproofed building.

Minimum Engineering Considerations

The design professional, a registered professional engineer or architect, must certify that the following requirements have been met by the building's design, specifications, and plans:

1. The building must be watertight (i.e., floodwaters must not enter the building envelope):
 - a. The building must be watertight to the floodproof design elevation, which is further defined as being at least the BFE. As previously noted, floodproofing to any elevation less than 1 foot above the BFE will have a serious negative impact on the flood insurance rating for the building. Generally a minimum of 1 foot of freeboard is recommended. Additional freeboard is warranted for sites where predicted flood depths may be inaccurate, such as sites within large drainage areas and rapidly urbanizing areas.
 - b. The building's walls must be "substantially impermeable to the passage of water." FEMA has adopted the U.S. Army Corps of Engineers (COE) definition of substantially impermeable from the COE publication "Flood Proofing Regulations." This document states that a substantially impermeable wall "shall not permit the accumulation of more than 4 inches of water depth during a 24-hour period if there were no devices provided for its removal. However, sump pumps shall be required to control this seepage." Flood-resistant materials, described in Technical Bulletin 2, "Flood-Resistant Materials Requirements," must be used in all areas where such seepage is likely to occur.
2. The building's utilities and sanitary facilities, including heating, air conditioning, electrical, water supply, and sanitary sewage services, must be located above the BFE, completely enclosed within the building's watertight walls, or made watertight and capable of resisting damage during flood conditions.
3. All of the building's structural components must be capable of resisting specific flood-related forces. These are the forces that would be exerted upon the building as a result of floodwaters reaching the BFE (at a minimum) or floodproofing design level, and include the following:
 - a. Hydrostatic Flood Force—This is the force that water at rest exerts on any submerged object. For a floodproofed building design, the calculations of hydrostatic flood forces must include saturated soil pressure on any portion of the building that is below grade (see Figure 1). Guidelines for determining hydrostatic pressure are provided on the following page.

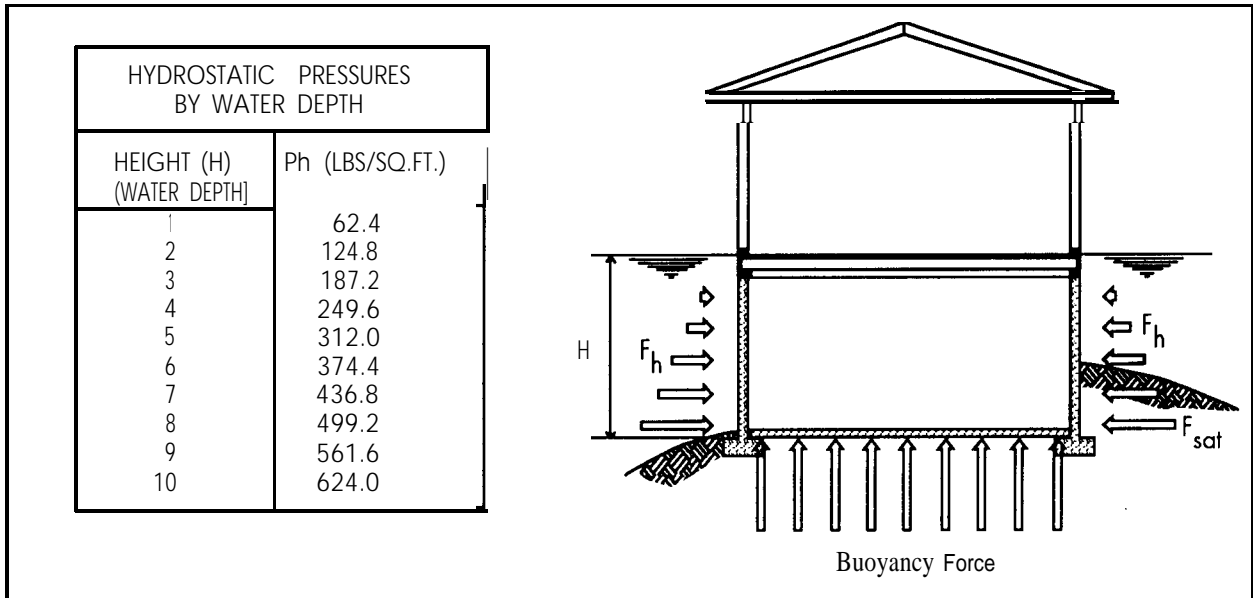

Figure 1. Hydrostatic Pressure Diagram

Resultant Lateral Force Due to Hydrostatic Pressure from Freestanding Water:

$$F_h = \frac{1}{2}wH^2$$

where: F_h is the lateral force from freestanding water (in pounds per linear foot of surface)

w is the specific weight of water (62.4 pounds per cubic foot)

H is the height of the standing water (to the floodproof design level)

If any portion of the building is below grade, then calculate the Resultant Cumulative Lateral Force Due to Hydrostatic Pressure from Saturated Soil:

$$F_{sat} = \frac{1}{2}SD^2 + F_h$$

where: F_{sat} is the lateral force from saturated soil

S is the equivalent fluid weight of saturated soil (in pounds per cubic foot)

D is the depth of saturated soil (in feet)

F_h is the lateral force from freestanding water

Note: See Appendix C of the FEMA "Design Manual for Retrofitting Flood-Prone Residential Structures" for further information.

- b. Buoyancy—This is the vertical force associated with the building's tendency to float when inundated or surrounded by floodwaters. This force can be calculated as shown below.

Buoyancy Force:

$$F_b = wAH$$

- where: F_b is the force due to buoyancy
- w is the specific weight of water (62.4 pounds per cubic foot)
- A is the area of horizontal surface (floor or slab) being acted upon (in square feet)
- H is the depth of building below the floodproofing design level (in feet)

Note: See Appendix C of the FEMA “Design Manual for Retrofitting Flood-Prone Residential Structures” for further information.

- c. Hydrodynamic Force—This is the force exerted on vertical surfaces exposed to moving floodwaters. The determination of hydrodynamic force is based on the expected velocity of the floodwaters with depths to the floodproofing design level (BFE or higher). The projected average base flood velocity within the floodway may be obtained using FEMA Flood Insurance Studies (FISS) where a floodway has been identified. It should be noted that velocities in the flood fringe will generally be less than the floodway velocities presented in the FIS. Where no FIS velocity data exist, velocities should be determined using Manning’s equation, as found in most hydraulic reference and text books.

Hydrodynamic Force:

$$F_d = C_d m^{1/2} (V)^2 A$$

- where: F_d is the lateral force due to hydrodynamic pressure
- C_d is the drag coefficient
- m is the mass density of water (1.94 slugs per cubic foot)
- V is the velocity of the water (in feet per second)
- A is the area of the wall affected (in square feet)

Note: See Appendix C of the FEMA “Design Manual for Retrofitting Flood-Prone Residential Structures” for further information.

- d. Debris Impact Force—This is the force associated with flood-borne debris striking the side of a building. This force presents the greatest unknown to the designer, but a value must be estimated to develop an effective floodproofing design. Unless more detailed information is available, such as historical debris flow data, the formula shown below should be used. This formula assumes a 1-second duration of impact. The weight of the object is generally estimated at 1,000 pounds but can be reduced to 500 pounds for areas subject to minor debris flow potential. Any areas subject to severe debris (such as mountainous regions or areas subject to ice floes) are not appropriate sites for floodproofed buildings unless the designer takes these forces into account in designing and armouring the building. Armouring often results in designs that are not cost-effective.

Debris Impact Force:

$$F_i = \frac{WV}{gt}$$

- where: F_i is the Impact Force
- w is the weight of the object (in pounds)
- v is the velocity of the object (in feet per second)
- g is the acceleration due to gravity (32.2 feet per second²)
- t is the duration of impact (in seconds)

Note: See Appendix C of the FEMA “Design Manual for Retrofitting Flood-Prone Residential Structures” for further information.

4. Like all construction that falls under the NFIP regulations, the building must meet the requirements of all applicable portions of local and State building codes, including the provisions of the Americans with Disabilities Act; life-safety codes for ingress, egress, and clearing; and venting and combustion air requirements.

Preparation of the Floodproofing Certificate for Non-Residential Buildings

The Floodproofing Certificate is required for all non-residential buildings to be floodproofed and is to be completed by the design professional. The first part of the Certificate contains information concerning the location and ownership of the building.

| | | |
|---|---------------------|---------------------------|
| FEDERAL EMERGENCY MANAGEMENT AGENCY NATIONAL FLOOD INSURANCE PROGRAM FLOODPROOFING CERTIFICATE FOR NON-RESIDENTIAL STRUCTURES | | O.M.B. No. 3067-007 |
| <i>The floodproofing of non-residential buildings maybe permitted as an alternative to elevating to or above the Base Flood Elevation; however, a floodproofing design certification is required. This form is to be used for that certification. Floodproofing of a residential building does not alter a community's floodplain management elevation requirements or affect the insurance rating unless the community has been issued an exception by FEMA to allow floodproofed residential basements. The permitting of a floodproofed residential basement requires a separate certification specifying that the design complies with the local floodplain management ordinance.</i> | | |
| | | FOR INSURANCE COMPANY USE |
| BUILDING OWNER'S NAME | POLICY NUMBER | |
| STREET ADDRESS (including Apt., Unit, Suite and/or Bldg. Number) OR P.O ROUTE AND BOX NUMBER | COMPANY NAIC NUMBER | |
| OTHER DESCRIPTION (Lot and Block Numbers, etc.) | | |
| CITY | STATE | ZIP CODE |

Building location and Ownership information

Section I of the Certificate is the Flood Insurance Rate Map (FIRM) information, including the BFE used in designing the floodproofing system. Copies of the FIRM should be available through the community's floodplain administrator.

| | | | | | |
|--|--------------|--------|--------------------|-----------|---|
| SECTION I FLOOD INSURANCE RATE MAP (FIRM) INFORMATION | | | | | |
| Provide the following from the proper FIRM: | | | | | |
| COMMUNITY NUMBER | PANEL NUMBER | SUFFIX | DATE OF FIRM INDEX | FIRM ZONE | BASE FLOOD ELEVATION (in AO Zones use depth) |
| | | | | | |

Section I

Section II requests information regarding the floodproofing design. The first item is the elevation, referenced to the datum of the FIRM (generally the National Geodetic Vertical Datum of 1929), to which the building is floodproofed. This elevation must be equal to or greater than the BFE. It is important to note that for insurance rating purposes, the floodproofing design must provide protection to 1 foot above the BFE to receive rating credit. If the building is floodproofed only to the BFE, then the building's insurance rating will result in a higher premium. Before a decision is made to floodproof to less than 1 foot above the BFE, insurance implications should be carefully considered.

The second item is the height of the floodproofing above the lowest adjacent grade. This information is intended to be used by community building officials, FEMA, and NFIP insurance underwriters to analyze the level of safety that the floodproofing design will provide. Since floodwaters exert greater pressure on the floodproofed building as the height of the flooding increases (see Figure 1), floodproofing that exceeds 3 feet in height represents a greater risk and may result in insurance rates that reflect this increased risk.

| |
|---|
| SECTION II FLOODPROOFING INFORMATION (By a Registered Professional Engineer or Architect) |
| <p>Floodproofing Design Elevation Information:</p> <p style="margin-left: 40px;">Building is floodproofed to an elevation of ____ feet NGVD. (Elevation datum used must be the same as that on the FIRM.)</p> <p style="margin-left: 40px;">Height of floodproofing on the building above the lowest adjacent grade is ____ feet.</p> <p style="margin-left: 40px;"><i>(NOTE: for insurance rating purposes, the building's floodproofed design elevation must be at least one foot above the Base Flood Elevation to receive rating credit. If the building is floodproofed only to the Base Flood Elevation, then the building's insurance rating will result in a higher premium.)</i></p> |

Section II

Section III is the actual certification of the floodproofing design as required in Section 60.3(c)(4) of the NFIP regulations. It is important to note that design professionals signing this form are certifying that they have developed and/or reviewed the design plans and specifications and find them in compliance with accepted standards of practice for dry floodproofing. This certification is based on the floodproofing design, not the as-built condition of the building. The person signing this form must be a registered professional engineer or architect within the state or territory where the building will be constructed or substantially improved.

SECTION III CERTIFICATION (By a Registered Professional Engineer or Architect)

Non-Residential Floodproofed Construction Certification:

I certify that based upon development and/or review of structural design, specifications, and plans for construction that the design and methods of construction are in accordance with accepted standards of practice for meeting the following provisions:

The structure, together with attendant utilities and sanitary facilities, is watertight to the floodproofed design elevation indicated above, with walls that are substantially impermeable to the passage of water.

All structural components are capable of resisting hydrostatic and hydrodynamic flood forces, including the effects of buoyancy, and anticipated debris impact forces.

I certify that the information on this certificate represents my best effort to interpret the data available. I understand that any false statement may be punishable by fine or imprisonment under 18 U.S. Code, Section 1001.

| | | | |
|------------------|--------------------------------|-------|-----|
| CERTIFIER'S NAME | LICENSE NUMBER (or Affix Seal) | | |
| TITLE | COMPANY NAME | | |
| ADDRESS | CITY | STATE | ZIP |
| SIGNATURE | DATE | PHONE | |

Copies should be made of this certificate for: 1) community official, 2) insurance agent/company, 3) building owner.

FEMA Form 81-65

Section III

The NFIP

The NFIP was created by Congress in 1968 to provide federally backed flood insurance coverage, because flood insurance was generally unavailable from private insurance companies. The NFIP is also intended to reduce future flood losses by identifying floodprone areas and ensuring that new development in these areas is adequately protected from flood damage. The NFIP is based on an agreement between the federal government and participating communities that have been identified as being floodprone. FEMA, through the Federal Insurance Administration (FIA), makes flood insurance available to the residents of a participating community provided that the community adopts and enforces adequate floodplain management regulations that meet the minimum NFIP requirements. The NFIP encourages communities to adopt floodplain management ordinances that exceed the minimum NFIP criteria. Included in the NFIP requirements, found under Title 44 of the U.S. Code of Federal Regulations, are minimum building design and

construction standards for buildings located in SFHAs. Through their floodplain management ordinances, communities adopt the NFIP design performance standards for new and substantially improved buildings located in floodprone areas identified on FIA's FIRMs.

Technical Bulletins

This is one of a series of Technical Bulletins FEMA has produced to provide guidance concerning the building performance standards of the NFIP. These standards are contained in Title 44 of the U.S. Code of Federal Regulations at Section 60.3. The bulletins are intended for use primarily by State and local officials responsible for interpreting and enforcing NFIP regulations and by members of the development community, such as design professionals and builders. New bulletins, as well as updates of existing bulletins, are issued periodically, as necessary. The bulletins do not create regulations; rather they provide specific guidance for complying with the minimum requirements of existing NFIP regulations. Users of the Technical Bulletins who need additional guidance concerning NFIP regulatory requirements should contact the Natural Hazards Branch of the appropriate FEMA regional office. The "User's Guide to Technical Bulletins" lists the bulletins issued to date and provides a key word/subject index for the entire series.

Ordering Information

Copies of the Technical Bulletins can be obtained from the appropriate FEMA regional office. Technical Bulletins can also be ordered from the FEMA publications warehouse. Use of FEMA Form 60-8 will result in a more timely delivery from the warehouse — the form can be obtained from FEMA regional offices and your state's Office of Emergency Management. Send publication requests to FEMA Publications, P.O. Box 70274, Washington, D.C. 20024.

Further Information

The following publications provide further information concerning non-residential floodproofing:

1. "Answers to Questions About Substantially Damaged Buildings," FEMA, May 1991, FEMA-213.
2. "Block and Brick Wall Integrity Against Water Heights and Systems and Materials to Prevent Flood Waters From Entering Buildings," Carl E. Pace, U.S. Army Corps of Engineers Waterways Experiment Station, Vicksburg, Mississippi, 1984.
3. "Commercial-Industrial Flood Audit," New England District, U.S. Army Corps of Engineers, n.d.
4. "Cooperative Flood Loss Reduction, A Technical Manual for Communities and Industries," Flood Loss Reduction Associates, 1981.
5. "Design Manual for Retrofitting Flood-Prone Residential Structures," FEMA, September 1986, FEMA-1 14.
6. "Floodproofing Non-Residential Structures," FEMA, May 1986, FEMA- 102.

7. "Flood Proofing Regulations," U.S. Army Corps of Engineers, March 1992, EP 1165-2-314.
8. "Human Stability in a High Flood Hazard Zone," S.R. Abt, R.J. Whittlen, A. Taylor, and D.J. Love, Water Resource Bulletin, August 1989.
9. "Sealants, Part 1," John P. Cook, Progressive Architecture, December 1974.
10. "Sealants, Part 2," John P. Cook, Progressive Architecture, February 1975.
11. "Systems and Materials to Prevent Flood Waters from Entering Buildings," U.S. Army Corps of Engineers, 1984.
12. "Tests of Brick-Veneer Walls and Enclosures for Resistance to Flood Waters," Carl E. Pace, U.S. Army Corps of Engineers, Lower Mississippi Division, Vicksburg, Mississippi, 1978.

Glossary

Base flood — The flood that has a 1-percent probability of being equaled or exceeded in any given year (also referred to as the 100-year flood).

Base Flood Elevation (BFE) — The height of the base flood, usually in feet, in relation to the National Geodetic Vertical Datum of 1929 or other datum as specified.

Basement — Any area of a building having its floor subgrade (below ground level) on all sides.

Coastal High Hazard Area — An area of special flood hazard extending from offshore to the inland limit of a primary frontal dune along an open coast and any other area subject to high-velocity wave action from storms or seismic sources.

Federal Emergency Management Agency (FEMA) — The independent federal agency that, in addition to carrying out other activities, oversees the administration of the National Flood Insurance Program.

Federal Insurance Administration (FIA) — The component of FEMA directly responsible for administering the National Flood Insurance Program.

Flood Insurance Rate Map (FIRM) — The insurance and floodplain management map issued by FEMA that identifies, on the basis of detailed or approximate analyses, areas of 100-year flood hazard in a community.

Floodprone area — Any land area susceptible to being inundated by floodwater from any source.

Lowest floor — The lowest floor of the lowest enclosed area of a building, including a basement. Any NFIP-compliant unfinished or flood-resistant enclosure useable solely for parking of vehicles, building access, or storage (in an area other than a basement) is @ considered a building's lowest floor.

Special Flood Hazard Area (SFHA) — Area delineated on a Flood Insurance Rate Map as being subject to inundation by the base flood and designated as Zone A, AE, A1-A30, AR, AO, AH, V, VE, or V1-V30.

Substantial damage — Damage of any origin sustained by a structure whereby the cost of restoring the structure to its before-damaged condition would equal or exceed 50 percent of the market value of the structure before the damage occurred.

Substantial improvement — Any reconstruction, rehabilitation, addition, or other improvement of a structure, the cost of which equals or exceeds 50 percent of the market value of the structure before the “start of construction” of the improvement. This term includes structures that have incurred “substantial damage,” regardless of the actual repair work performed.